



## 2250 VALVE POSITION INDICATOR SYSTEM

### DATA SHEET



#### APPLICATION

The HDI 2250 Valve Position Indicator (VPI) System allows the user to monitor the position of manual and hydraulically actuated gate valves found primarily on the choke manifold. Traditionally, manual gate valves do not have a position indicator found on the valve. The 2250 System solves this problem by adding an adapter onto the valve, while not compromising the integrity or certification of the valve, to give the user valve position locally. The user can also remotely see the position of all valves being monitored on a virtual P&ID of the entire manifold.

The 2250 can be utilized for non-rising stem gate valves taking into account various bonnet sizes and manufacturers. Once installed, this System has little maintenance. The VPI System can be easily integrated with HDI's V9000 Virtual Choke Console System and has been field proven for over 5 years offshore.

#### FEATURES

- Adapts to various manual gate valve sizes and models
- Does not compromise the integrity of the valve being monitored
- Namur and proximity switch capabilities
- Local and remote visual displays of valve position

#### OPTIONS

- Remote virtual position with client specific P&ID
- Integration with HDI V9000 Virtual Choke Console System

#### CERTIFICATIONS

- Comprised of components certified for Class 1, Division 1 hazardous environments

**SAFETY**  
**PRECISION**  
**INNOVATION**

WELL CONTROL MONITORING AT ITS FINEST

## SPECIFICATIONS

- Weight : 15.3 lbs with Junction Box mounted
- Case Material: 316 Stainless Steel
- Sensor: Inductive Namur Sensor
- Sensor Power : Non-Rising Stem Gate Valves

## DIMENSIONS

All dimensions given are in inches and [millimeters] unless otherwise noted.

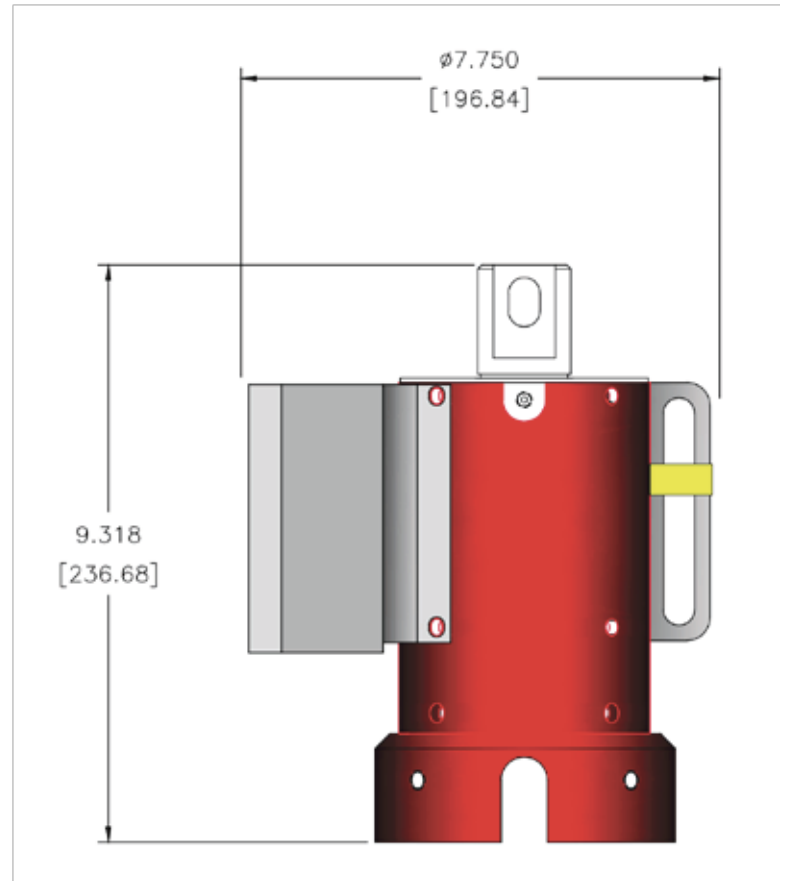

Lower adapter diameter will change and is dependent on valve bonnet